

Schib® CO 90E Flow Wrapper



Features

- High Speed wrapper for hard candy and chewing gum
- Up to 2,000 ppm
- User-Friendly Controls
- Allen-Bradley programmable automation controller
- 10" color touch screen offering HMI functionality
- Allen-Bradley Kinetix servo drives
- Feeding Disk
- Twin reel holders (automatic splicer as an option)
- Reel run out sensor
- Motorized film pre-feed
- Photocell registration for printed films
- Serrated end seals for easy opening
- Temperature control integrated into control panel
- 2 to 6 jaws configurations

Schib® CO 90E Flow Wrapper

The state-of-the-art Schib CO 90E is a horizontal flow-pack machine specifically designed for candies and other small size confectionery products such as pellets, bubble gums, lozenges, toffees, tablets and lollipops. Its design evolves from 50 years of industry expertise and engineering excellence, coupled with the ultimate automation and motion solution from Allen-Bradley.

Several configurations of this model are available, including lollipop versions, customized feeders for hard-boiled candies, molded products and marshmallows, and multi-feeders for balls to be wrapped in assorted colors.

Schib's key strength is long-term customer relationships based on consistent performance and after-sales support that surpasses expectations. We provide complete service, from design concept to installation and commissioning, followed by lifetime support.

Feature	Standard	Optional
Min./Max. product dimensions	Length 15 / 50 mm Width 5 / 50 mm Height 1 / 30 mm	
Performance	1500 ppm	Up to 2000 ppm
Film roll width and max. ext. dia	150 mm / 350 mm	
Drive	4 servo + 3 asynchronous motors	
Sealing head	Rotary	
In-feed conveyor useful length	1000 mm	On request
Automatic film splicer	No	Yes
Machine exit	Static chute	Exit belt
Control panel	Color touch-screen	
Program memory	40 programs	99 programs
Diagnostics	Yes	
Machine finishing	Painted RAL 9007	Stainless steel
Product sorting unit	No	Yes
Wrapping materials	Heat sealable OPP - BOPP - COEX laminate	Cold-sealable films
Installed / absorbed power	10 / 4 kW	
Weight	1500 kg	
Feeding system	Feeding disk	
Machine dimensions	4178 x 1463 x 1740 mm	
We reserve the right to make technical changes without prior notice.		



Ideal for Hard and Soft Candies



Feeding Disk



Automatic Film Splicing (optional)

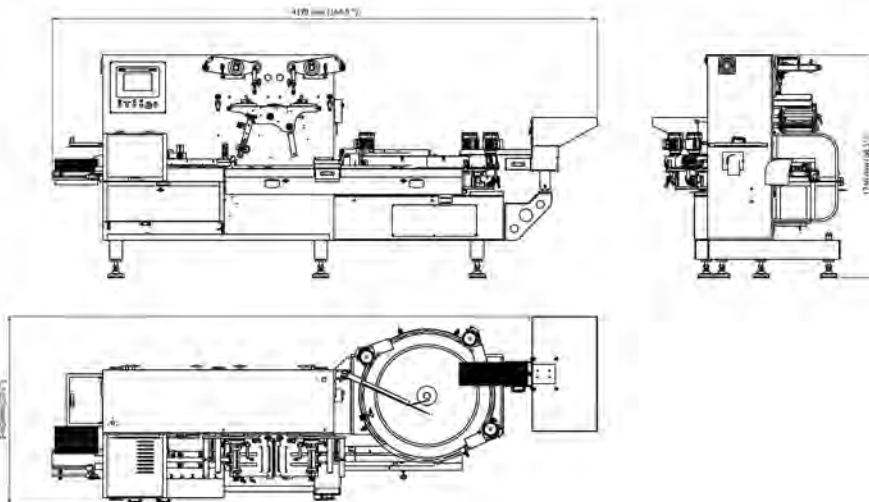

bwflexiblesystems.com

Global Operations

Duncan | SC | 29334 USA
t. +1 (864) 486 4000

Nottingham | NG9 1LA UK
t. +44 (0) 115 967 8787

Mestrino (PD) | 35035 ITALY
t. +39 049 9006511

Monte di Malo (VI) | 36030 ITALY
t. +39 0445 602300

Hayssen | Rose Forgrove | Sandiacre | Schib | Simionato | Streamfeeder | Symach | Thiele

BW Flexible Systems is a global manufacturer of packaging systems that fill and bag thousands of food and non-food products. Our packaging systems are designed and manufactured to maximize the efficiency and lifetime value of our customers' packaging lines. Our range of machinery includes form-fill-seal, feeding, bag filling and sealing, pouch-making equipment, flow-wrap, reclosable packaging solutions, palletizing, stretch-wrapping and more. For more information, go to bwflexiblesystems.com

barrywehmiller
bw
betterworld

2022.04